

## Evaluation environment of MIMO high-speed wireless LAN

### \*Application\*

Recently, some wireless LAN equipment are shifting to high-throughput MIMO from SISO in order to correspond to the increasing traffic. In addition, RFIC for wireless LAN is built into various electronic devices besides information communication terminal, and the trend is getting stronger. A useful system when developing and evaluating a radio equipment with wireless LAN will be introduced in this application note.

### \*Solution\*

#### 1. Cable connection diagram

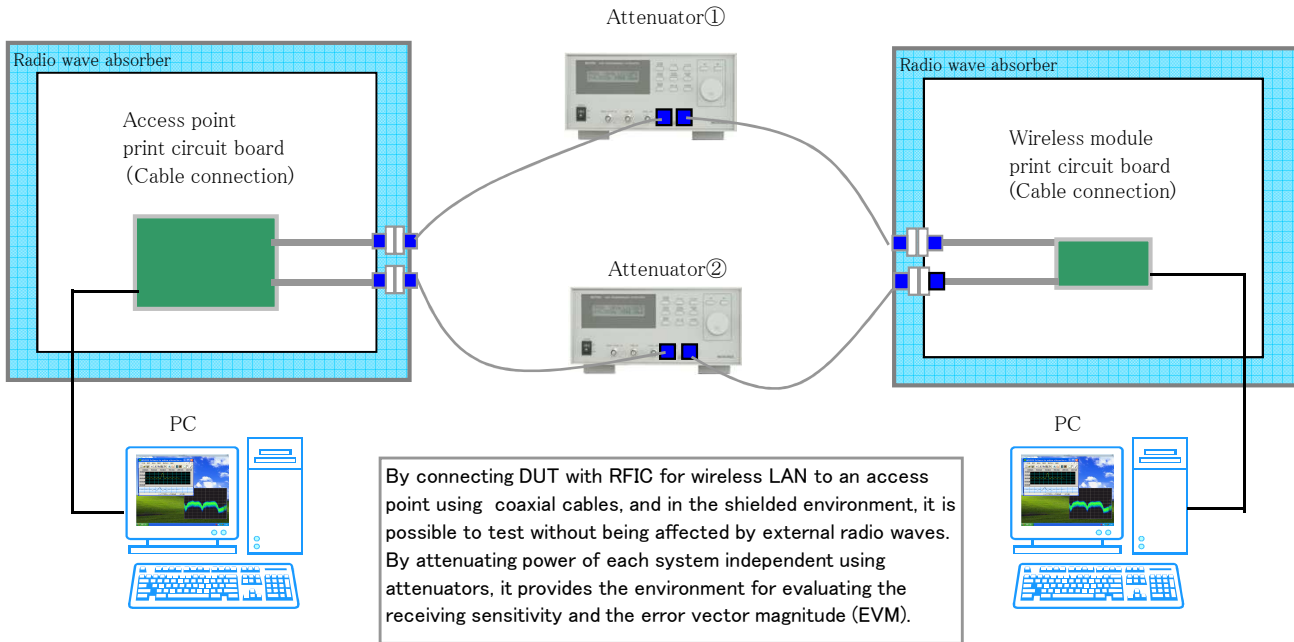

#### 2. Wireless connection diagram

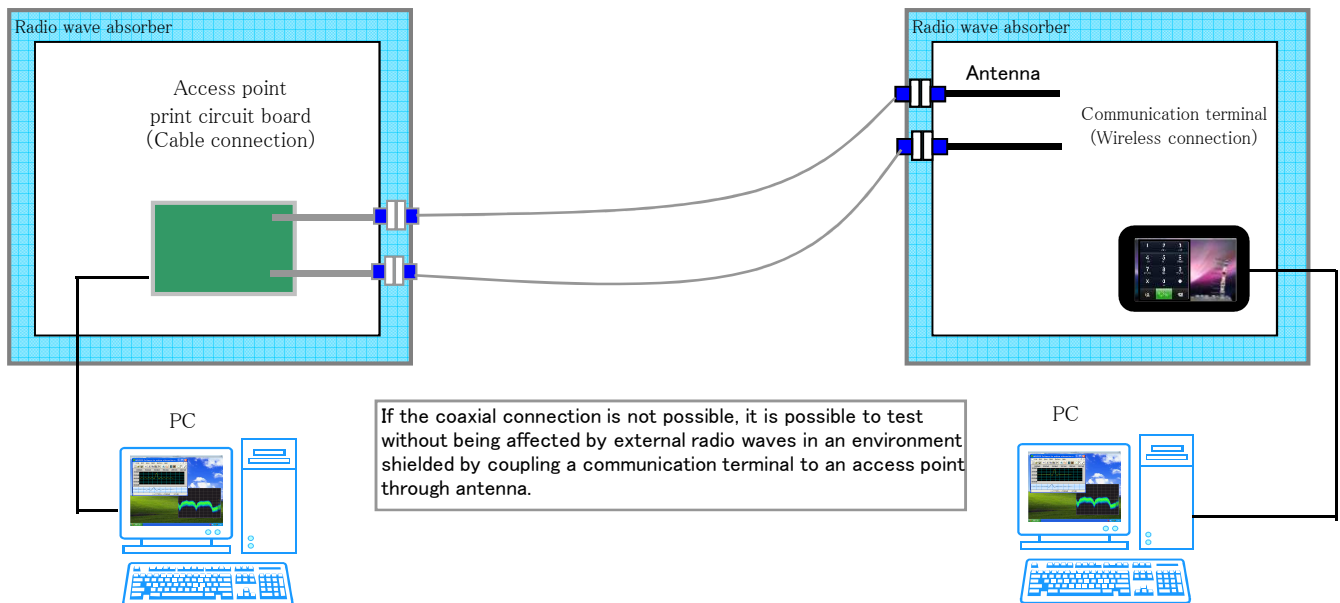

1. Cable connection diagram    Anechoic box :MY1510, MY1515, MY1520, Programmable attenuator:MAT800/D  
2. Wireless connection diagram    Anechoic box :MY1520, MY1530

2011/2